

Sheet and panel lifters are important lifting aids in the wood industry and in many other types of manufacturing processes including steel sheets.

TAWIGrip is a safe and reliable lifter for materials with airtight surface and semi-airtight surfaces. Sheet metal, glass and laminated panels can be lifted and tilted.

The gripping tool is completely pneumatic with a choice between two compressed air

TAWIGrip PNEUMATIC VACUUM LIFTER

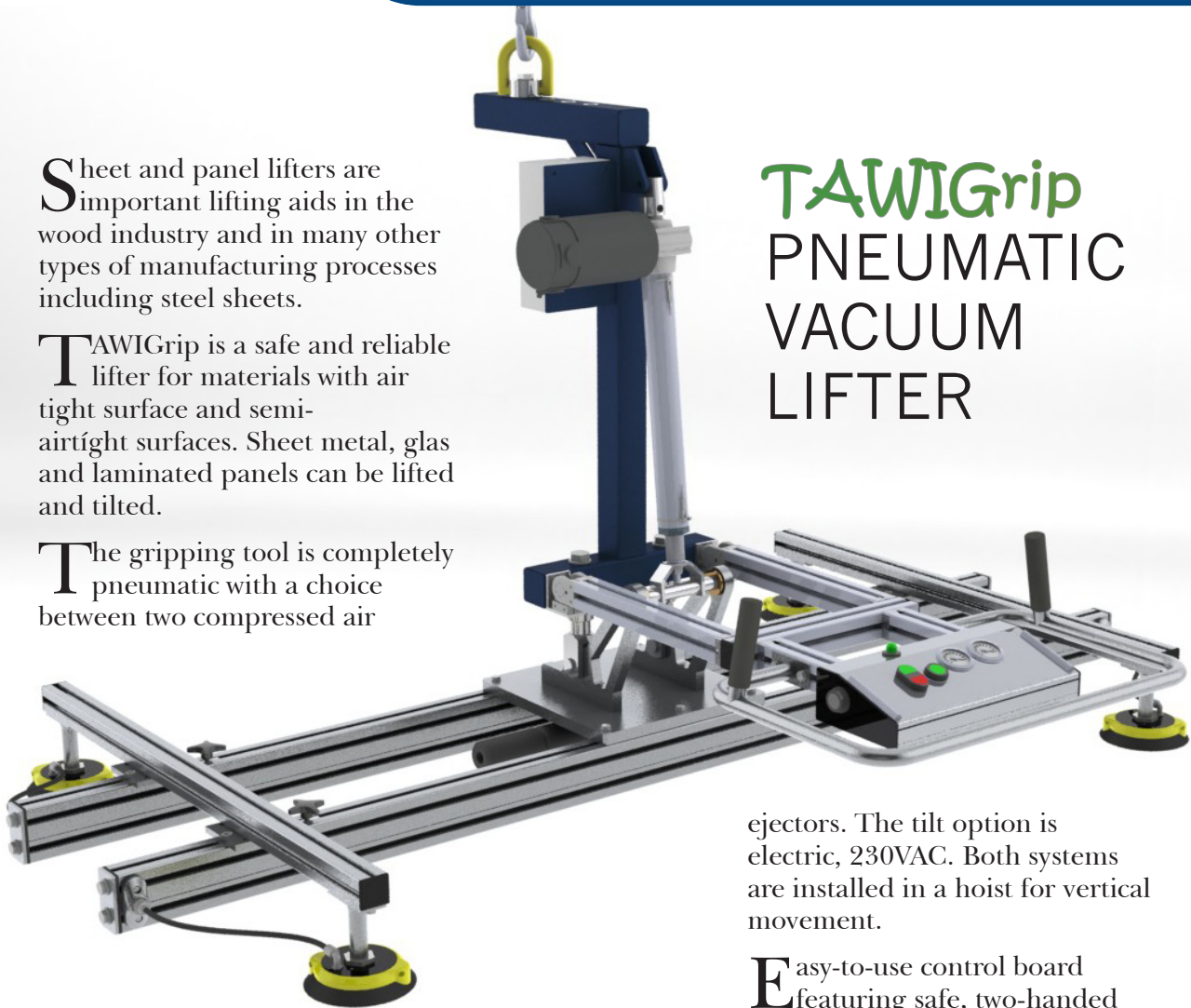

ejectors. The tilt option is electric, 230VAC. Both systems are installed in a hoist for vertical movement.

Easy-to-use control board featuring safe, two-handed release function and visual control of the vacuum level. All models have a safety system based on a twin-chamber vacuum unit. The ergonomic adjustment of the handle bar includes fixed and flexible option.

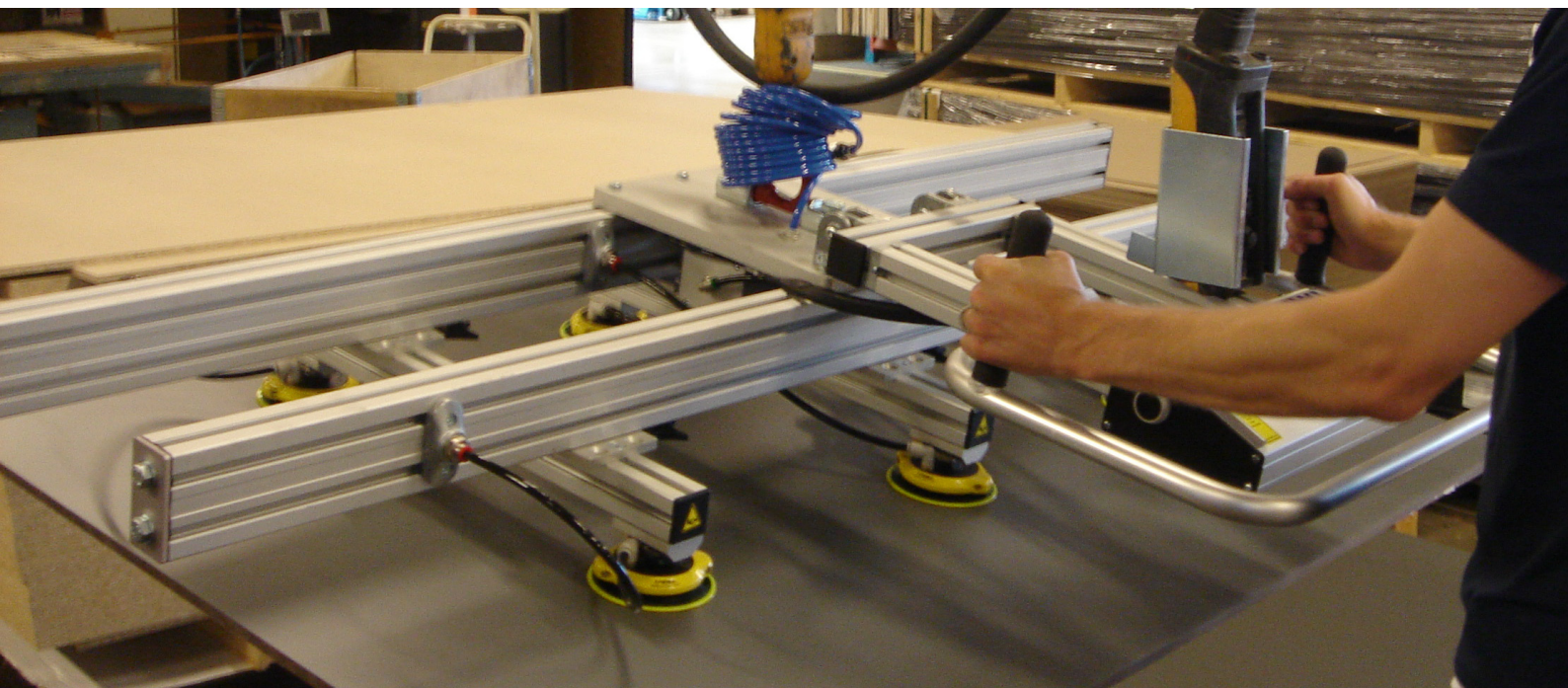

- 1. Choose Lift or Lift & Tilt
- 2. Find Max cap. = load weight
- Suction cup is NOT included!

TAWIGrip vacuum yoke					
TYPE	Max cap./cup	Art nr	No. of cups*	A (mm) max	B (mm) max
Lift	250 kg	759040	4	2410	1180
	250 kg	759060	6		
	250 kg	759080	8		
	500 kg	759640	4	2910	1430
	500 kg	759660	6		
	500 kg	759680	8		
Lift & tilt 90°	250 kg	758040	4	2410	1180
	250 kg	758060	6		
	250 kg	758080	8		

*Suction cups are not included in the vacuum yoke

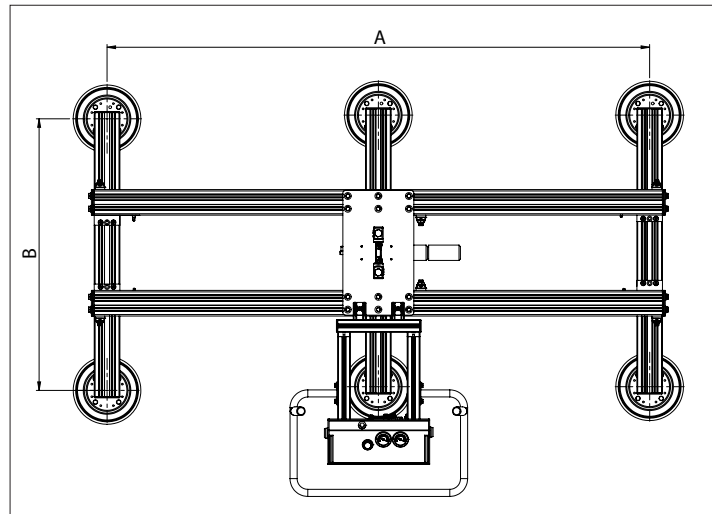

EXAMPLE 1: Yoke (759660) max 500 kg, with 6 suction cups (756060)

- 3. Find suitable Characteristics
- 4. Find suitable Capacity/cup = nr of cups

Choice of suction cup (examples):				
Type	CHARACTERISTICS, SUITABILITY:	HORIZONTAL Cap./cup	TILT Cap./cup	DIA (mm)
756030	Smooth surface	21 kg	12 kg	Ø112
756020	Smooth surface	42 kg	30 kg	Ø152
756030	Smooth/rough surface, non-marking	25 kg	20 kg	Ø115
756050	Smooth/domed/oily surface, non-marking	35 kg	38 kg	Ø150
756010	Bellow cup, level adjustment, separate small/thin objects	34 kg	- (0 kg)	Ø155/166
756060	Heavy objects, smooth surface	95 kg	- (0 kg)	Ø238
756070	Heavy objects, smooth surface	215 kg	- (0 kg)	Ø347

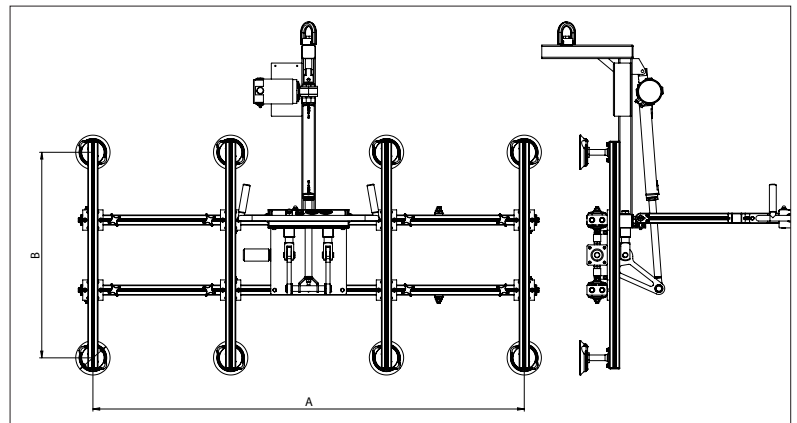

EXAMPLE 2: TILT Yoke (758080) max 250 kg, with 8 suction cups (756020)

5. Calculate positioning of suction cups over load surface:

OVERHANG (X mm) steel/aluminium:		OVERHANG (X mm) glass:	
Thickness	Max overhang	Thickness	Max overhang
0,5	350	4	508
1	550	5	635
1,5	650	7	736
2	750	8	812
3	950	10	889
4	1100	13	1041
5	1200	16	1168
8	1500	20	1270
10	1650	23	1371
12	1950	26	1473
15	2150		
20	2350		
25	2700		

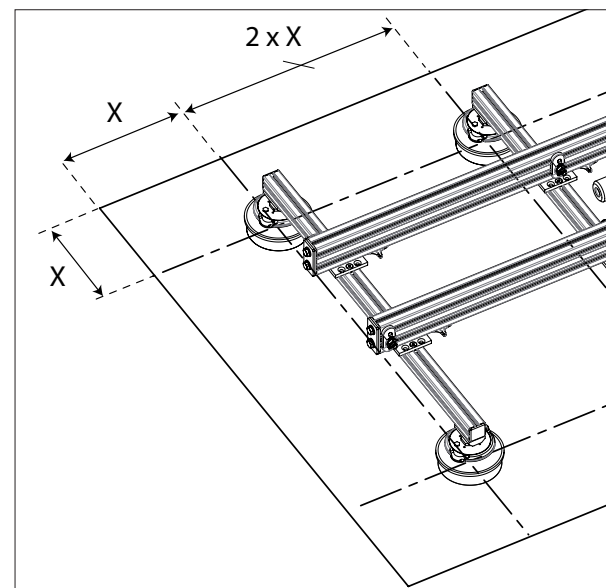

Specification overhang